

CUET UG – 2022

PHYSICS

Question : 1

Electric potential due to dielectric dipole on equatorial line at distance r from the centre of the dipole is (P = dipole moment) (assume dipole as very short).

A $V = \pm \frac{1}{4\pi\epsilon_0} \frac{P}{r^2}$

B $V = \pm \frac{1}{4\pi\epsilon_0} \frac{2P}{r^2}$

C $V = \pm \frac{1}{4\pi\epsilon_0} \frac{P}{r^3}$

D $V = 0$

Question : 2

The electrostatic force between the plates of an isolated parallel plate capacitor having charge Q and area of each plate A is:

A $\frac{Q^2}{2A\epsilon_0}$

B $Q^2 2A\epsilon_0$

C $\frac{\sigma}{2\epsilon_0}$

D $\frac{Q}{2A\epsilon_0}$

Question : 3

Two point charges $q_A = 3\mu\text{C}$ and $q_B = -3\mu\text{C}$ are located 2 m apart in vacuum. The electric field at midpoint of the line joining the two charges is:

- A $5.4 \times 10^4\text{ N/C}$
- B $1.35 \times 10^4\text{ N/C}$
- C $2.7 \times 10^4\text{ N/C}$
- D Zero

Question : 4

Figure shows electric field lines in which an electric dipole \vec{p} is placed as shown. Which of the following statements is correct?

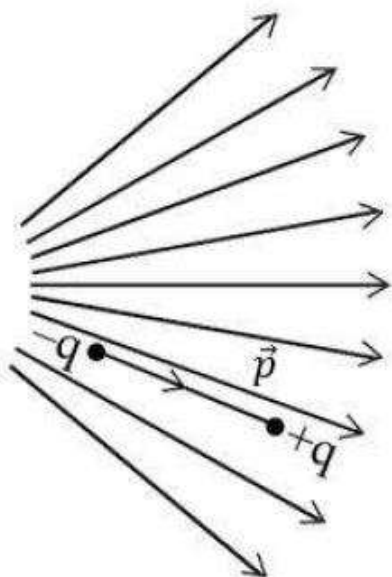

- A The dipole will not experience any force
- B The dipole will experience a force in the direction of \vec{p}
- C The dipole will experience a force opposite to \vec{p}
- D The dipole will experience a force perpendicular to \vec{p}

Question : 5

A system consisting of two point charges $7\mu\text{C}$ and $-4\mu\text{C}$ are placed at $(-9, 0, 0)$ cm and $(9, 0, 0)$ cm respectively. The electrostatic potential energy of the system is:

- A -0.7 J
- B -1.4 J
- C -3.6 J
- D -6.8 J

Question : 6

Variation of Electric field intensity due to a uniformly charged conducting spherical shell of radius R with the distance from the centre of the shell can be represented by following graph:

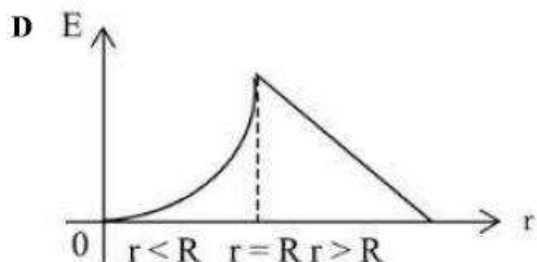
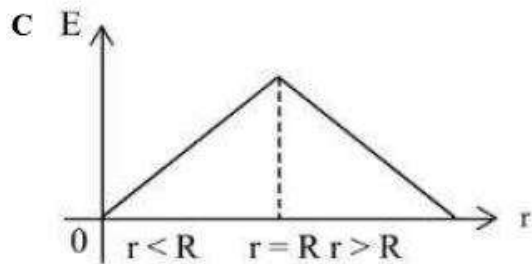
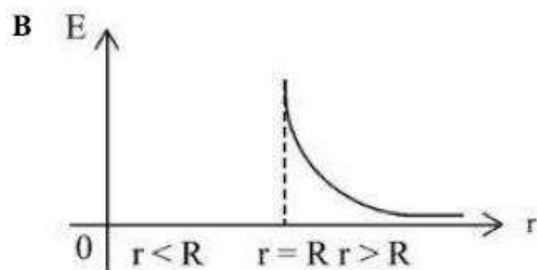
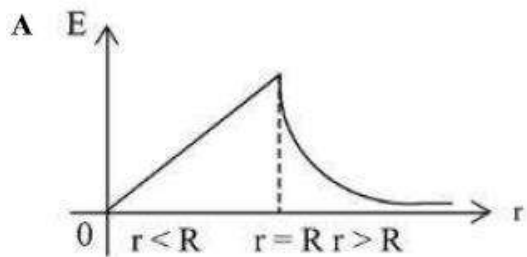

Question : 7

A uniform magnetic field \vec{B} is established along the positive z-direction. A rectangular loop of sides 'a' and 'b' carries a current of I as shown in figure. The torque in the loop is:

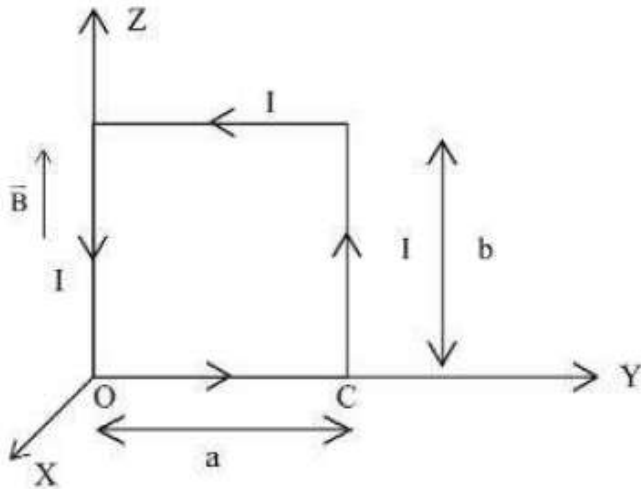

- A $IabB (-\hat{j})$
- B $IabB (\hat{j})$
- C $IabB (\hat{k})$
- D $IabB (\hat{i})$

Question : 8

A charged particle with charge q and mass 'm' is moving with velocity 160 ms^{-1} in the region of magnetic field B at an angle 60° with the direction of \vec{B} . The pitch of helix formed by particle will be:

- A $\frac{100\pi m}{qB}$
- B $\frac{120\pi}{qB}$
- C $\frac{160\pi m}{qB}$
- D $\frac{80\pi m}{qB}$

Question : 9

In an atom, an electron with charge 'e' and mass m is revolving around the nucleus in a specific orbit with angular momentum (\vec{L}) and the equivalent magnetic dipole moment ($\vec{\mu}$)

of that atom is : $\vec{\mu} = -\frac{e}{2m} \vec{L}$, where $\frac{e}{2m}$ will be:

- A Bohr's Magnetron
- B Gyromagnetic Ratio
- C Specific charge of electron
- D Orbital Magnetic moment

Question : 10

A solenoid of length 0.5 m and radius 10 cm has 500 turns. If a current of 5 A flows through it, the magnetic field produced inside the solenoid will be:

- A 1.4×10^{-3} T
- B 2.8×10^{-3} T
- C 4.8×10^{-3} T
- D 6.28×10^{-3} T

Question : 11

Two long parallel conductors separated by a certain distance 'd' and carrying steady currents I_1 and I_2 are shown in figures. Choose the correct statement.

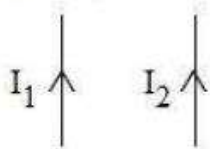

Figure - 1

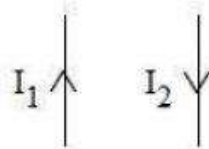

Figure - 2

- A In figure 1 conductors repel each other and In figure 2 they attract each other
- B In figure 1 conductors attract each other and In figure 2 they repel each other
- C In both the figures conductors attract each other
- D In both the figures conductors repel each other

Question : 12

Which of the following statements related to magnetic materials are correct?

- A. Diamagnetic materials get strongly magnetized in an external magnetic field.
- B. Ferromagnetic materials get strongly magnetized in an external magnetic field.
- C. Paramagnetic materials get weakly magnetized in an external magnetic field.
- D. Soft iron is a suitable material for the core of electro-magnets.
- E. For diamagnetic materials, magnetic susceptibility is positive and small.

Choose the correct answer from the options given below:

- A A, B, E only
- B B, C, E only
- C B, C, D only
- D C, D, E only

Question : 13

In a solenoid, if number of turns per unit length is doubled, then self inductance will become:

- A half of its initial value
- B double of its initial value
- C $\frac{1}{4}$ times of its initial value
- D 4 times of its initial value

Question : 14

The current in a coil falls from 5.0 A to 0.0 A in 0.1 s. If average emf of 200 V is induced, the value of self inductance of coil is:

- A 2 H
- B 4 H
- C 3 H
- D 1 H

Question : 15

A bulb and an iron core inductor are connected to an AC source through key as shown in figure:

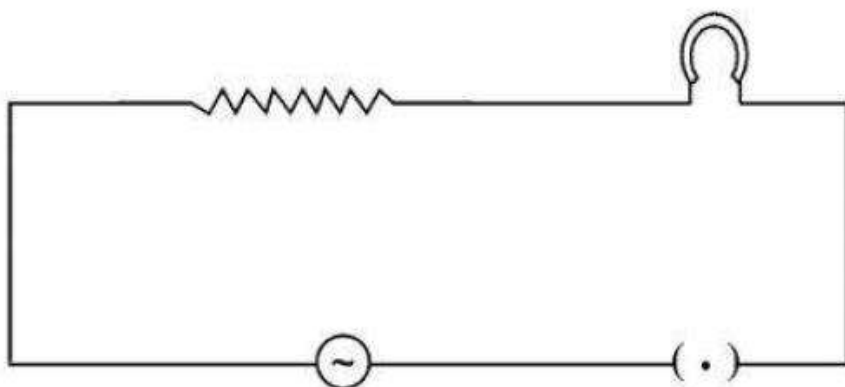

The bulb glows with certain brightness. Now iron rod is taken out of the inductor. Then the brightness of bulb:

- A increases
- B decreases
- C is unchanged
- D first increases then decreases

Question : 16

Match List I with List II

List I (Physical quantity)	List II (SI unit)
A. Self-Inductance	I. Weber
B. Magnetic	II. Volt
c. Impedance	III. Henry
D. Induced emf	IV. Ohm

Choose the correct answer from the options given below:

- A A-III, B-I, C-II, D-IV
- B A-III, B-I, C-IV, D-II
- C A-I, B-III, C-IV, D-II
- D A-I, B-III, C-II, D-IV



Question : 17

A 50Ω resistance and an inductance of $\frac{2}{3\pi} H$ are connected in series with power supply of 220 Volt AC of 50 Hz. Choose the correct statement:

- A Current leads the potential difference by $\tan^{-1}\left(\frac{3}{4}\right)$
- B Potential difference leads the current by 90°
- C Current leads the potential difference by $\tan^{-1}\left(\frac{4}{3}\right)$
- D Potential difference leads the current by $\tan^{-1}\left(\frac{4}{3}\right)$

Question : 18

Given figure shows a plane coil is moving with velocity v with respect to N-pole of a bar magnet. The correct interpretation of induced current is given in figure:

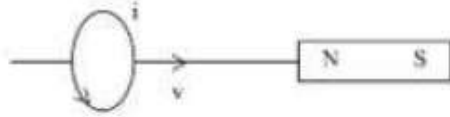
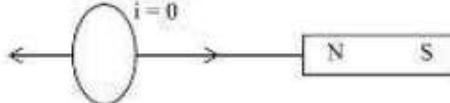
- A 
- B 
- C 
- D 

Question : 19

The electromagnetic waves which can be used to destroy cancer cells are:

- A. Ultra Violet Rays
- B. Gamma Rays
- C. Infrared Rays
- D. X-Rays
- E. Microwaves

Choose the correct answer from the options given below:

- A A, B and E only
- B B and D only
- C C, D and E only
- D A and E only

Question : 20

Two electromagnetic waves have the frequencies as 4×10^{14} Hz and 8×10^{14} Hz. The ratio of their speeds in air is:

- A 1:2
- B 1:4
- C 1:1
- D 2:1

Question : 21

A beam of light consisting of two wavelengths 5000 \AA and 6000 \AA is used to obtain interference fringes in Young's double slit experiment. The least distance from the central maxima where the bright fringes due to both wavelengths coincide, will be:

(If separation between slits = 1 mm & separation between slits & screen is 1 m)

- A 4 mm
- B 3 mm
- C 2 mm
- D 1 mm

Question : 22

In an interference pattern , the ratio of intensity of two waves is $\frac{9}{25}$, then the ratio of maximum intensity to minimum intensity is:

- A 16 : 1
- B 1 : 9
- C 3 : 5
- D 5 : 3

Question : 23

Which of the following statements are true:

For refraction of white light through a glass prism at minimum deviation position of prism.

- A. The angle of prism becomes zero.
- B. Angle of refraction at first refracting surface r_1 is equal to angle of refraction at second refracting surface r_2 .
- C. The refracted ray inside the prism is parallel to the base of the prism.
- D. Angle of emergence becomes 90° .
- E. Angle of incidence is equal to angle of emergence.

Choose the correct answer from the options given below:

- A B, C and E only
- B A, C and D only
- C B, C and D only
- D A, D and E only

Question : 24

A convex lens of refractive index 1.55, with both the surfaces of the same radius of curvature has a focal length of 20 cm. The radius of curvature of the surface will be:

- A 20 cm
- B 22 cm
- C 24 cm
- D 26 cm

Question : 25

Match List I with List II

List I	List II
A. Convex mirror	I. Accommodation
B. Total Internal Reflection	II. Reflecting type
C. Ciliary muscles	III. Optical Fiber
D. Cassegrain Telescope	IV. Used as a rear view mirror

Choose the correct answer from the options given below:

- A A-IV, B-I, C-III, D-II
- B A-IV, B-III, C-I, D-II
- C A-II, B-III, C-I, D-IV
- D A-I, B-III, C-IV, D-II

Question : 26

Match List I with List II

List I (Lens)	List II (Focal Length)
A. Double Convex Mirror	I. $f = \frac{R}{(1 - n_g^a)}$
B. Plane Convex Lens	II. $f = \frac{R}{2(n_g^a - 1)}$
C. Double Concave Lens	III. $f = \frac{R}{(n_g^a - 1)}$
D. Plano Concave Lens	IV. $f = \frac{R}{2(1 - n_g^a)}$

Choose the correct answer from the options given below:

- A A-II, B-I, C-IV, D-III
- B A-II, B-III, C-IV, D-I
- C A-II, B-III, C-I, D-IV
- D A-IV, B-III, C-II, D-I

Question : 27

In Young's double slit experiment using monochromatic light of wavelength λ , the intensity of light at a point on the screen where path difference λ is K units. What is the intensity of light at a point where path difference is $\frac{\lambda}{3}$?

- A $\frac{K}{6}$
- B $\frac{K}{4}$
- C $\frac{K}{2}$
- D $\frac{K}{8}$

Question : 28

The interference pattern is said to be sustained if the position and intensity of fringes remain same throughout on the screen. For sustained interference:

- A. The size of slits must be large.
- B. Two sources must be coherent.
- C. Screen must be very close to slits.
- D. Separation between the slits must be small.
- E. The screen must be placed close to the plane of slits.

Choose the correct answer from the options given below:

- A A and C only
- B B only
- C B and D only
- D B, D and E only

Question : 29

A converging beam of rays is incident on a concave lens. After passing through the lens, the rays converge at a distance of 15 cm from the lens on the other side. If the lens is removed, the converging point of rays decreases by 5 cm. The focal length of lens is:

- A -10 cm
- B -20 cm
- C -30 cm
- D -5 cm

Question : 30

The Kinetic Energy of an electron having de Broglie wavelength triple, then the de Broglie wavelength associated with it becomes:

- A $\frac{\lambda}{3}$
- B $\lambda\sqrt{3}$
- C $\frac{\lambda}{\sqrt{3}}$
- D 3λ

Question : 31

Identify the correct statement according to Einstein's picture of photoelectric effect:

- A Maximum Kinetic Energy of electrons depends linearly on frequency of incident radiation.
- B Maximum Kinetic Energy of electrons depends linearly on intensity of incident radiation.
- C The photoelectric current is independent of intensity of incident radiation.
- D Intensity of incident radiation is directly proportional to the frequency of radiation.

Question : 32

According to photon picture of electromagnetic radiation, which of the following statements is incorrect?

- A Each photon has energy and momentum.
- B Each photon moves with speed of light in vacuum.
- C Photons are electrically neutral.
- D In a photon-electron collision, the total energy and total momentum are not conserved.

Question : 33

The relation between half-life of a radio nuclide denoted by $T_{\frac{1}{2}}$ and average life of a radio nuclide denoted by τ , is:

A $T_{\frac{1}{2}} = \tau \ln 2$

B $\tau = T_{\frac{1}{2}} \ln 2$

C $T_{\frac{1}{2}} = \frac{1}{\tau}$

D $T_{\frac{1}{2}} = \tau$

Question : 34

Arrange the following steps involved in working of photodiode in sequential order of their occurrence.

- A. Electron hole pair generation
- B. Absorption of photons
- C. Illumination with light
- D. Separation of electron-hole pair
- E. Collection of electrons in n-side and holes in p-side.

Choose the correct answer from the options given below:

- A D, E, B, A, C
- B C, B, A, D, E
- C C, A, D, B, E
- D B, C, A, D, E

Question : 35

For a Common-Emitter amplifier, the audio signal voltage across the collector resistance of $2\text{ k}\Omega$ is 2 V . Suppose the current amplification factor of the transistor is 100 . The base resistance is $1\text{ k}\Omega$. The input signal voltage will be:

- A 0.02 V
- B 0.04 V
- C 0.03 V
- D 0.01 V

Question : 36

Choose the correct answer from the following options:

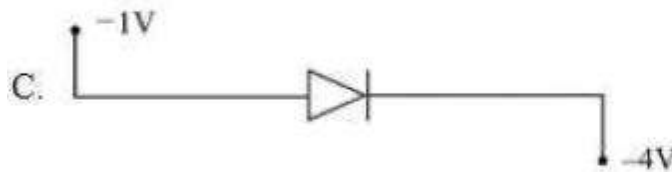
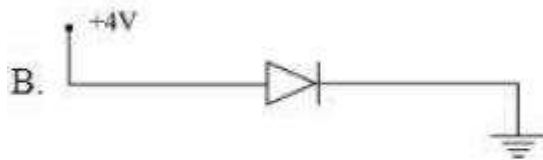
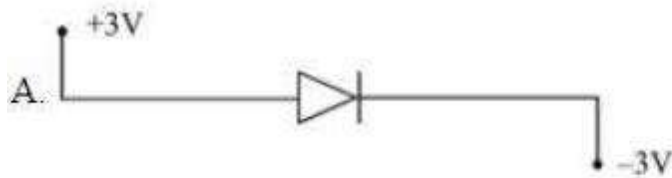

- A Only diode A is in forward biasing.
- B Just two diodes A and B are in forward biasing.
- C All diodes A, B and C are in forward biasing.
- D None of the diodes A, B and C are in forward biasing.

Question : 37

The following figure shows device X with input and output signals. The device is:

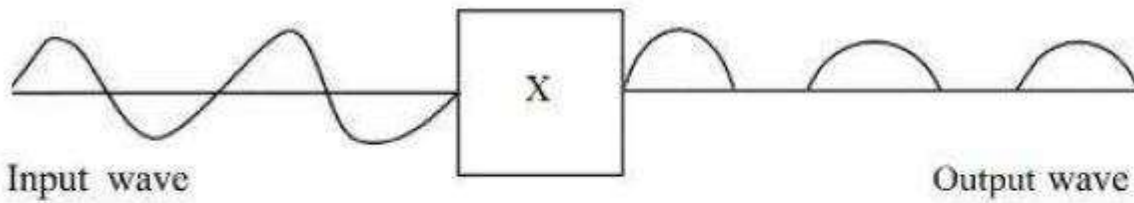

- A Half wave Rectifier
- B Full wave Rectifier
- C Transistor
- D Transformer

Question : 38

Choose the logic operation for the following circuits:

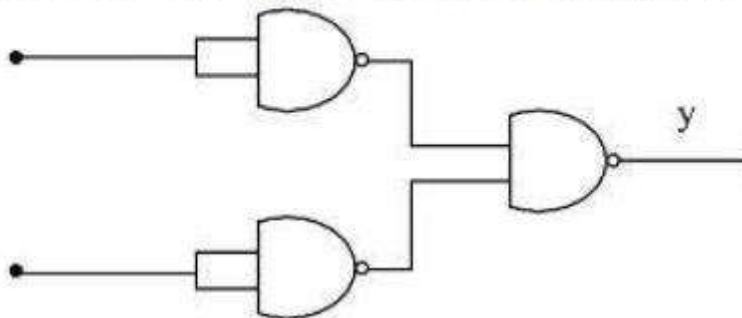

- A OR
- B AND
- C NOR
- D NAND

Question : 39

A block diagram of a typical receiver in a communication system is as shown in figure. The various components in correct sequence is:

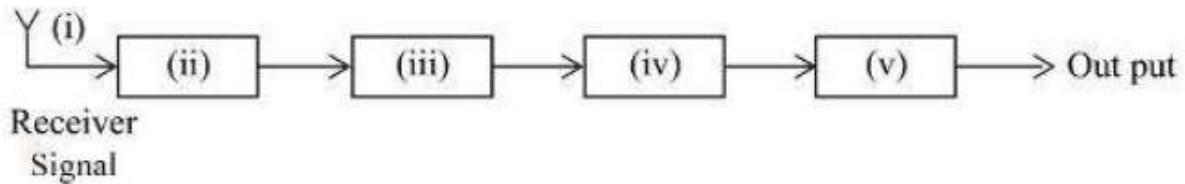

- A. Detector
- B. Amplifier 1
- C. IF stage
- D. Amplifier 2
- E. Receiving Antenna

Choose the correct answer from the options given below:

- A (i)-E, (ii)-B, (iii)-D, (iv)-C, (v)-A
- B (i)-E, (ii)-B, (iii)-C, (iv)-A, (v)-D
- C (i)-E, (ii)-D, (iii)-A, (iv)-B, (v)-C
- D (i)-E, (ii)-A, (iii)-B, (iv)-C, (v)-D

Question : 40

In the detection of amplitude modulated wave, the carrier frequency is usually changed to a long frequency by:

- A Amplifier
- B Detector
- C IF stage
- D Receiving Antenna

Passage:

We are introduced to the Bohr model of atom one time or the other in the course of physics. This model has its place in the history of quantum mechanics and particularly in explaining the structure of an atom. It has become a milestone since Bohr introduced the revolutionary idea of definite energy orbits for the electrons, contrary to the classical picture requiring an accelerating particle to radiate. Bohr also introduced the idea of quantisation of angular momentum of electrons moving in definite orbits. Thus, it was a semi-classical picture of the structure of atom.

Now with the development of quantum mechanics, we have a better understanding of the structure of atom. Solutions of the Schrodinger wave equation assign a wave-like description to the electrons bound in an atom due to attractive forces of the protons.

An orbit of the electron in the Bohr model is the circular path of motion of an electron around the nucleus.

- Bohr model is valid only for one-electron atoms/ions; an energy value, assigned to each orbit, depends on the principal quantum number n in this model. We know that energy associated with a stationary state of an electron depends on n only. For one-electron atoms/ions. For a multi-electron atom/ion, this is not true.

Question : 41

According to Bohr postulates, wavelength of spectral lines can't be determined for

- A Na
- B Li^{++}
- C He^+
- D H

Question : 42

Bohr's quantisation conditions:

- A Charge is quantised
- B Angular momentum is quantised
- C Circumference of electron orbit is quantised
- D Energy is quantised

Question : 43

Ground state energy of electron in Hydrogen atom is -13.6 eV. De-Broglie wavelength of electron in 2^{nd} excited state is:

- A 13.6 \AA
- B 3.77 \AA
- C $3.18\pi \text{ \AA}$
- D $9.54\pi \text{ \AA}$

Question : 44

Bohr's model of atom is:

- A Classical picture of atomic structure
- B Semi-classical picture of atomic structure
- C Quantum picture of atomic structure
- D Standing wave picture of atomic structure

Question : 45

In the Hydrogen Spectrum provided by Bohr's model, spectral series falls in ultra-violet region of E.M. wave is:

- A Lyman series
- B Balmer series
- C Paschen series
- D Brackett series

Passage:

A cell is a source of electric current in the electrical circuit. The Potential Difference between terminals of a cell in an open circuit (when no current is drawn) is called electromotive force (emf) of the cell. When electrical circuit is closed and current is drawn from the terminal Potential Difference between two terminals is called terminal potential difference (v) of the cell. The cells can be connected in series as well as in parallel combinations. Like resistor cell also offers opposition to the flow of current. This opposition offered by cell is called internal resistance of the cell.

Question : 46

Two cells of emf's \mathcal{E}_1 and \mathcal{E}_2 and respective internal resistances r_1 and r_2 are connected in parallel as shown in figure. The effective emf will be:

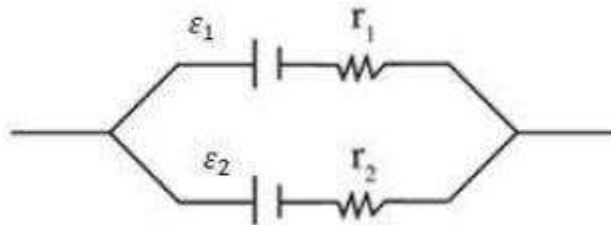

- A $\frac{\mathcal{E}_1 r_1 + \mathcal{E}_2 r_2}{r_1 + r_2}$
- B $\frac{\mathcal{E}_1 r_2 + \mathcal{E}_2 r_1}{r_1 + r_2}$
- C $\frac{\mathcal{E}_1 r_2 - \mathcal{E}_2 r_1}{r_1 - r_2}$
- D $\frac{\mathcal{E}_1 r_1 - \mathcal{E}_2 r_2}{r_1 + r_2}$

Question : 47

Three cells, each of emf ε and internal resistance r are connected with external resistor R as shown in fig. The value of current (I) flowing in the circuit will be:

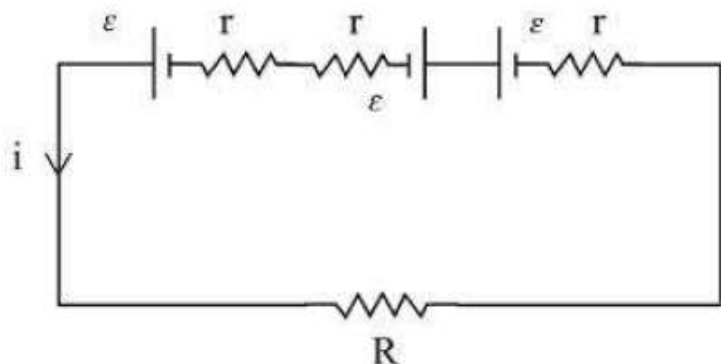

- A $\frac{3\varepsilon}{R + 3r}$
- B $\frac{2\varepsilon}{R + r}$
- C $\frac{\varepsilon}{R + 3r}$
- D Zero

Question : 48

When a cell is connected across external resistance 5Ω , a current of 0.25 A flows through the circuit. If the external resistance is replaced by 2Ω , a current of 0.5 A flows through it. The emf of the cell in the circuit is:

- A 0.75 V
- B 1 V
- C 1.25 V
- D 1.5 V

Question : 49

The variation of terminal potential difference of a cell with current drawn from the cell is correctly represented by:

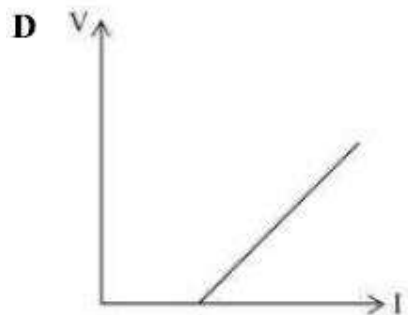
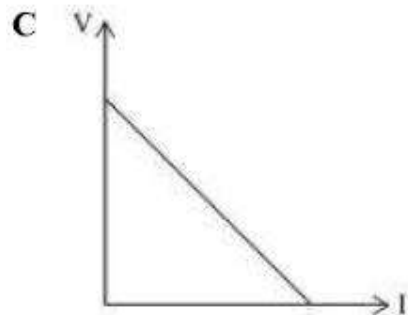
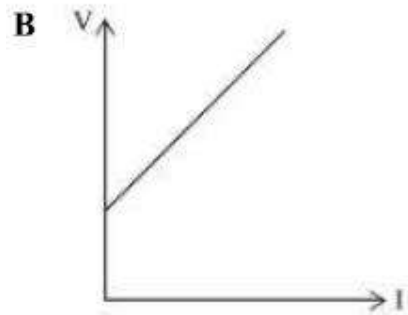
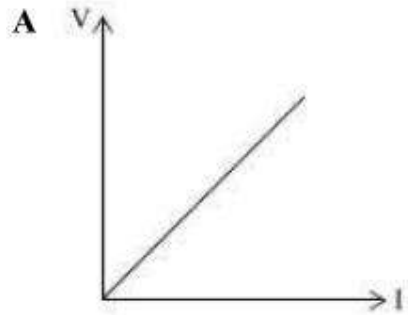

Question : 50

Two identical cells each of emf ε and internal resistance r when connected in series or in parallel across external resistance R give the same value of current. Then the relation between r and R is:

A $r = R$

B $r = 2R$

C $r = \frac{R}{2}$

D $r = \frac{3R}{2}$